



For Powerful Digital Marketing and Total Multimedia Solution

DV-66U

Specification & Manual

Operation mode - Normal

Input device:

1. Control Board with 8 key switches
2. Touch Panel
3. PIR sensor

Setting Example:

Control Board with 8 key switches

- a. Make sure the control board (DV-66U) is properly connected to the DV-66B.
- b. Turn the power ON. The LED on DV_66U (midst red) will light on. (Normal mode)
- c. Press control board key SW1~8 (tact switch), then the player will play file accordingly
1 for file 001.xxx, SW2 for file 002.xxx,, SW8 for file 008.xxx. (Key# mapping to file#).
- d. Or you can use 8 big push button switches to control the 66U (GND is common Ground to all 8 switches, SW1-8 map PIN socket are wired for 8 switches.), those keys are mapping to files sequence like as SW 1~8.

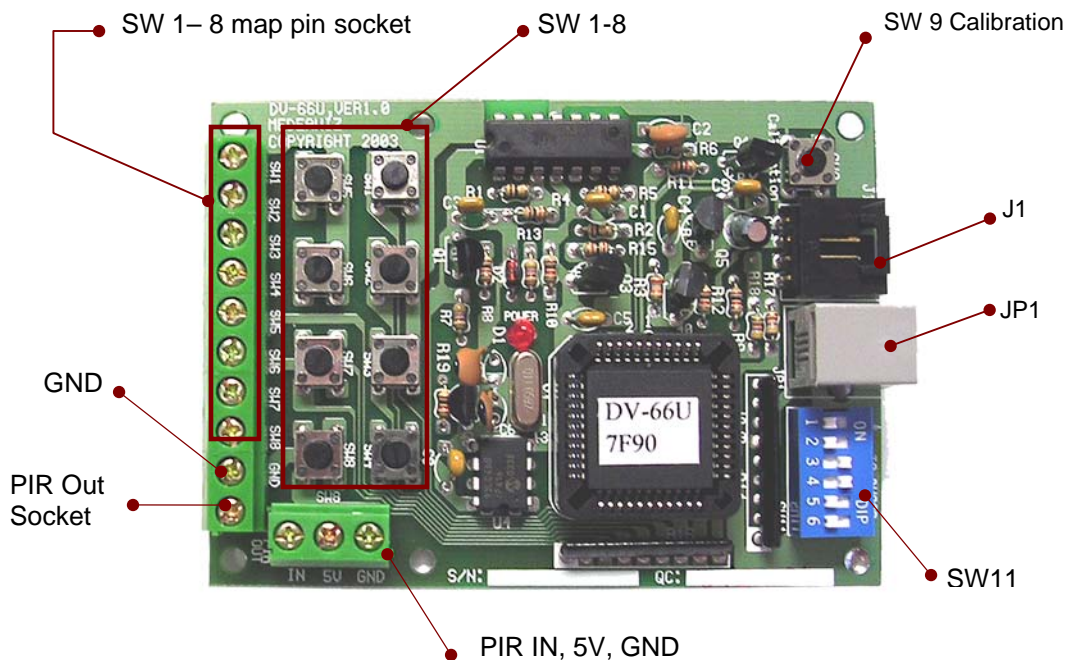

Touch Panel

Make sure the control board (DV-66U) and touch panel are properly connected. Touch the touch panel first area (the area 1st on it), it will homologize to file 1st to play; analogous for the next.

- a. The touch screen can be divided into 6 x 4, 3 x 2, or 1 x 4 different Matrix type by DIP SW setup. (Be sure that the SW11 DIP SW configuration is set correctly as below table.)
- b. Touch screen default setup as Matrix type of 6 x 4 for 24 selections.

Remark: Touch screen need to be calibrated before used. Please see next chapter for the calibration process of the touch screen.

Touch screen matrix definition for 6x4, 3x2, 1x4 after calibration

SW11	DIP #3	On	On	Off	Off
	DIP #4	On	Off	On	Off
Touch Screen SW type:		X6 x Y4	X3 x Y2	X1 x Y4	NA

1. Touch Screen SW type: X6 x Y4

	X1	X2	X3	X4	X5	X6
Y1	SW1	SW2	SW3	SW4	SW5	SW6
Y2	SW7	SW8	SW9	SW10	SW11	SW12
Y3	SW13	SW14	SW15	SW16	SW17	SW18
Y4	SW19	SW20	SW21	SW22	SW23	SW24

2. Touch screen SW type: X3 x Y2

	X1	X2	X3	X4	X5	X6
Y1	SW1	SW1	SW2	SW2	SW3	SW3
Y2	SW1	SW1	SW2	SW2	SW3	SW3
Y3	SW4	SW4	SW5	SW5	SW6	SW6
Y4	SW4	SW4	SW5	SW5	SW6	SW6

3. Touchj Creen SW type: X1 x Y4

	X1	X2	X3	X4	X5	X6
Y1	SW1	SW1	SW1	SW1	SW1	SW1
Y2	SW2	SW2	SW2	SW2	SW2	SW2
Y3	SW3	SW3	SW3	SW3	SW3	SW3
Y4	SW4	SW4	SW4	SW4	SW4	SW4

PIR

- Turn off power on DV-66B and remove cable before you link the 3 wires to PIR.
- The PIR has 3 wires (5V, Ground, PIR signal In) that can be connected to the socket of PIR (see the socket configuration on the left-down corner of the photograph below)
- Connect the PIR out socket to SW1 with a wire, plug the cable on the JP1, and then power on DV-66B. When PIR sensor senses someone approaching, it will let the player to play file 001.xxx (menu mode); analogous for one of the other 7 switches if connected.
(**Remark:** The PIR will ONLY start to be activated about 30 seconds after power is on.)

Remark: The user can decide which file to be played (by any one of the SW1 to SW 8 wired to PIR out socket) when the PIR activated.

Operation Mode: Calibration & Setup

Configuration and Definition:

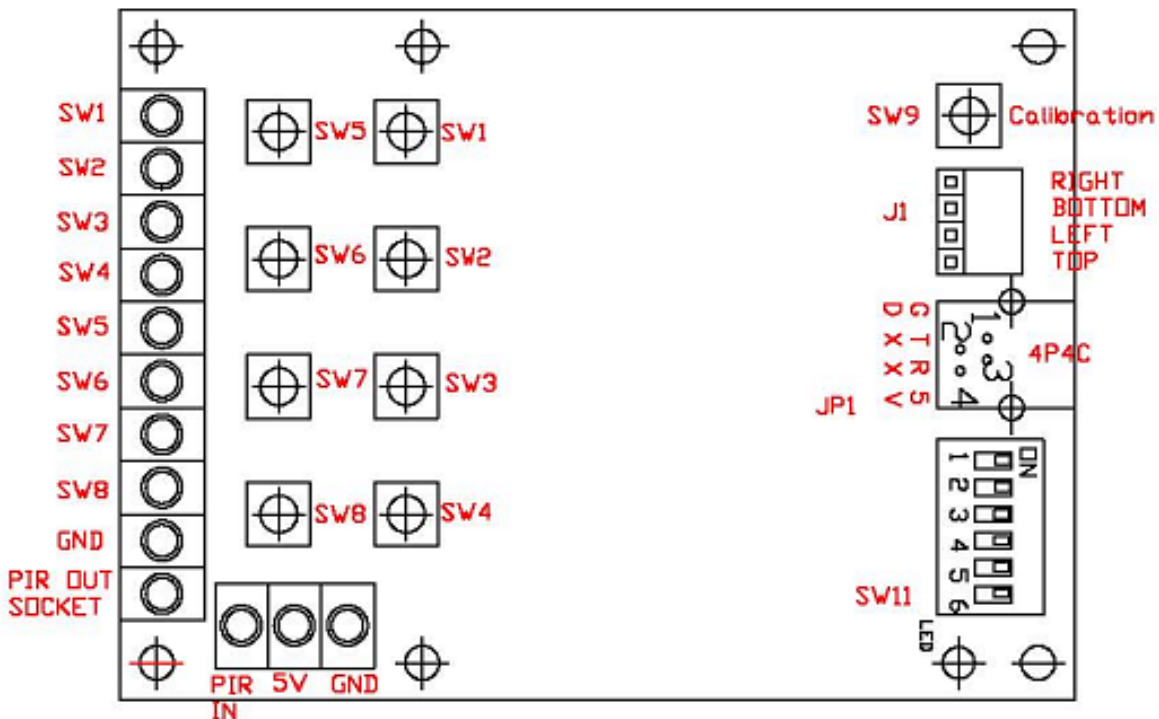

Control Board with 8 key switches

JP1: Connect to DV-66B socket

SW 1~8: Mapping to DV-66B storage inside File by name sequence

PIN socket: Map from SW 1~8

GND: Common ground for SW 1~8 sockets' wiring.

PIR

PIR 5V: Vcc, DC Power for PIR

PIR GND: ground, DC Power for PIR

PIR in: Trigger input from PIR, when it received trigger, the activated signal will output to PIR out socket.

The DV-66 player will play mapping file on the SW# which PIR out socket wired with.

PIR out: Trigger output to the selected SW (SW1 to SW8) to play the mapping file when PIR sensor activated.

Touch Panel

SW 9: Switch for Calibration of touch panel

SW 11: Dip Switch to set DV-66U touch screen SW type.

J1: Analog Touch Panel socket (see the drawing above for 4-pin wirings)

Note: It should be wires of the resistive analog touch screen - RIGHT, BOTTOM, LEFT, TOP as drawing above)

SW11 Default Setting

Dip	On/Off
1	Off
2	Off
3	ON
4	ON
5	Off
6	Off

SW11 DIP SW 3,4 function check list

DIP SW#				
3	On	On	Off	Off
4	On	Off	On	Off
Touch field Type	6 x 4	3 x 2	1 x 4	NA

* Preparing a CompactFlash© card that has 17 calibration special files (please download those files from MedeaWiz web site under Downloads) and insert it into DV-66B before it power ON.

Calibration Example (proceeded in "Repeat" mode only):

1. Setup the DV-66B at Repeat mode, copy the 17 specific calibration files into the CF card.
2. Before connect the DV-66U to the DV-66B, turn on the DV-66B first and DV-66B will repeat playing the 17 files.
3. Proceed to connect touch panel to J1 with correct "Right, Bottom, Left, Top " wires and setup the DIP SW at 6 x 4 mode.
4. Press and hold "Calibration" key of SW 9, then power on the DV-66U by plug in the cable from DV-66B into JP1connector of DV-66U.
5. Centered LED on DV-66U will be blinking 3 times and then off, it means the unit is already at "Calibration setup mode".
6. The DV-66B will play the fig. 1 (file 001.jpg) and waiting for touch screen input.
7. Using a touch pen to press at center of the red dot in Fig. 1 and hold for more than 3 seconds when the first file played. (Refer to fig. 1), then the centered LED will be blinking 3 times then off.
8. It will show "Touch Screen Calibration OK for this point, release for next." (Fig.16), then release the touch pen and wait a few seconds to play the Fig. 2. You will see next point for calibration on the screen.
9. Repeat the procedures of above item 7& 8 until all 15 points on Screen was calibrated.
10. "Touch Screen Calibration finished " message will appear when the 15th point is calibrated (Fig.17), the DV-66U has finished calibration now. The calibration data will be stored in the flash memory of the DV-66U. (Touch screen will be divided into 6 x 4 matrix as Fig. 18).

11. Turn off the DV-66B and remove the CF card that contains 17 calibration files, then insert the CF card with the desired media files.
12. Adjust the SW11, DIP SW setup to select the matrix type that you would like to use. The DV-66U is already calibration and can start to work now.

Calibration Special files images:

Fig.1 (file: 001.jpg)



Fig. 16 (file: 016.jpg)



Fig.2 (file: 002.jpg)

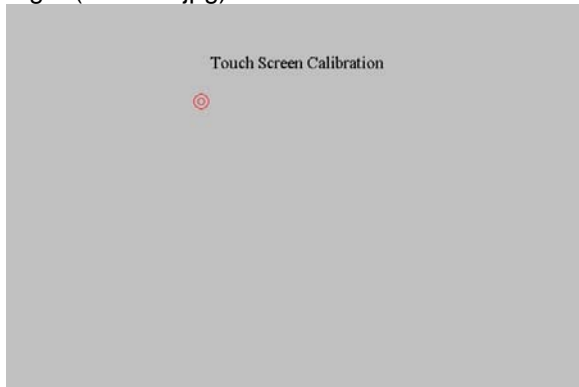

Fig. 16 (file: 016.jpg)

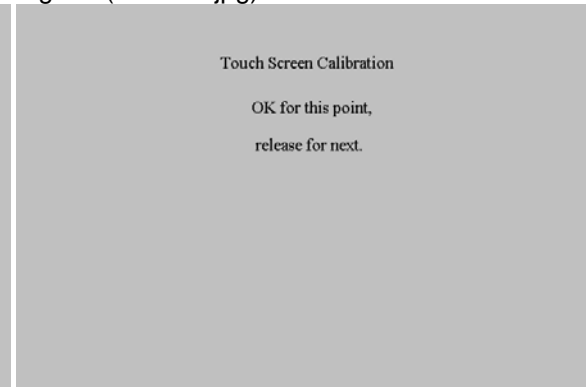

Fig.3 (file: 003.jpg)

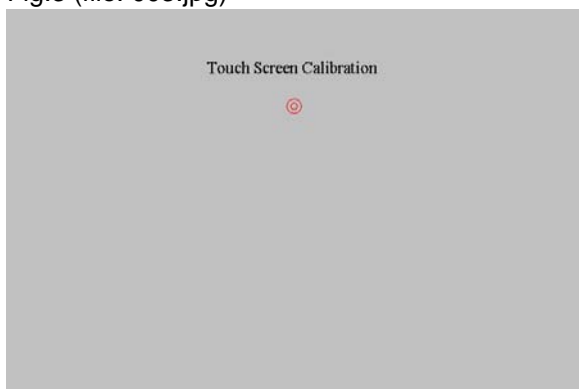

Fig. 16 (file: 016.jpg)

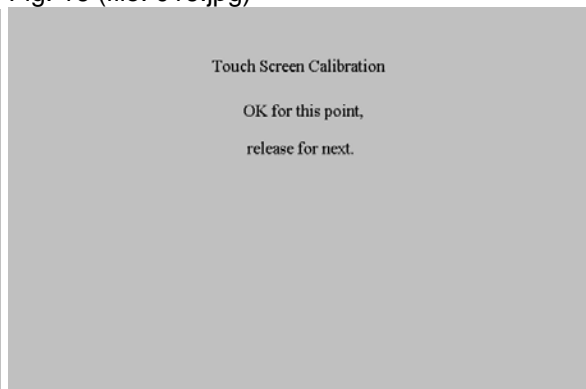

Fig.4 (file: 004.jpg)

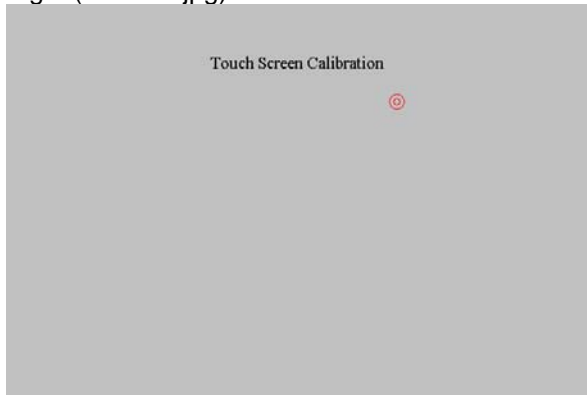

Fig. 16 (file: 016.jpg)

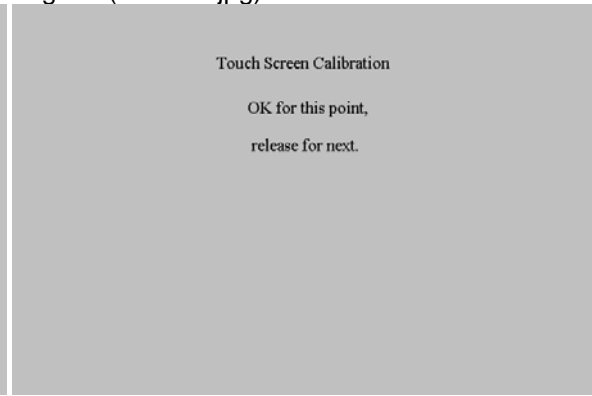

Fig.5 (file: 005.jpg)

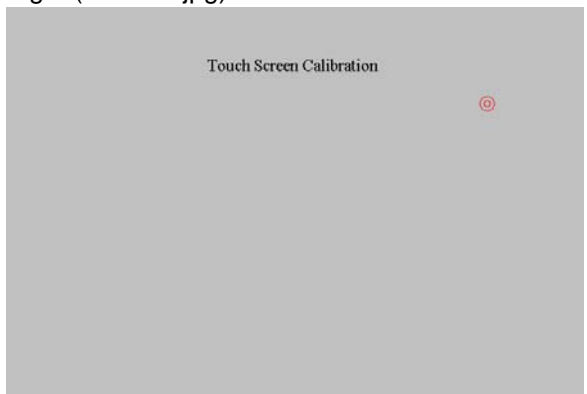

Fig. 16 (file: 016.jpg)

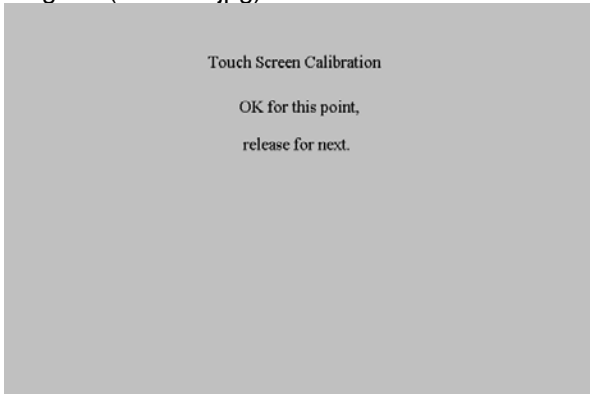

Fig.6 (file: 006.jpg)

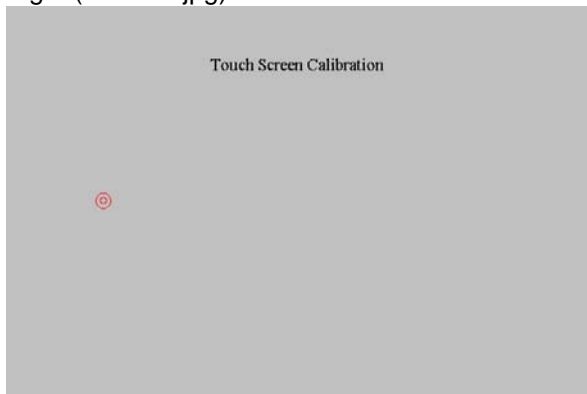

Fig. 16 (file: 016.jpg)

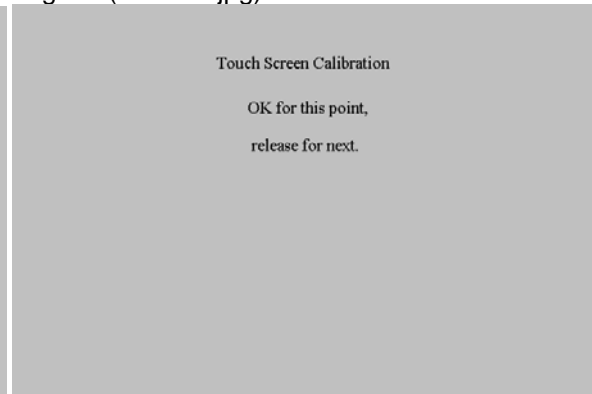

Fig.7 (file: 007.jpg)

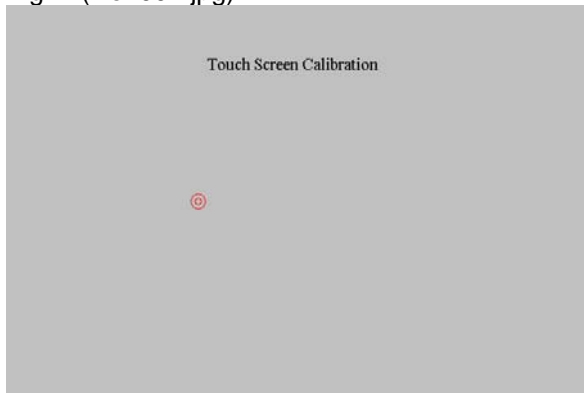

Fig. 16 (file: 016.jpg)

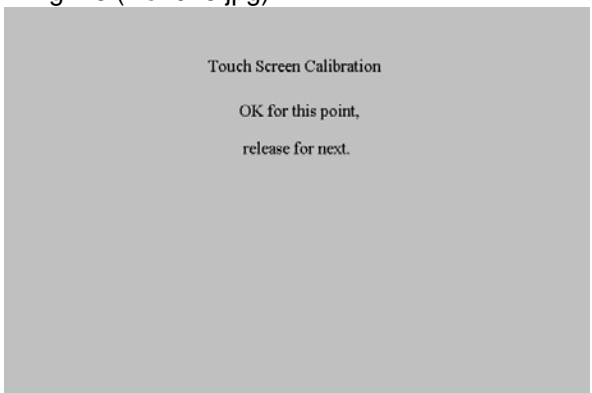

Fig.8 (file: 008.jpg)

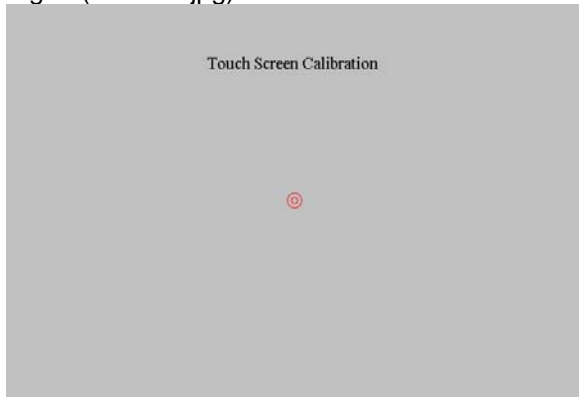

Fig. 16 (file: 016.jpg)

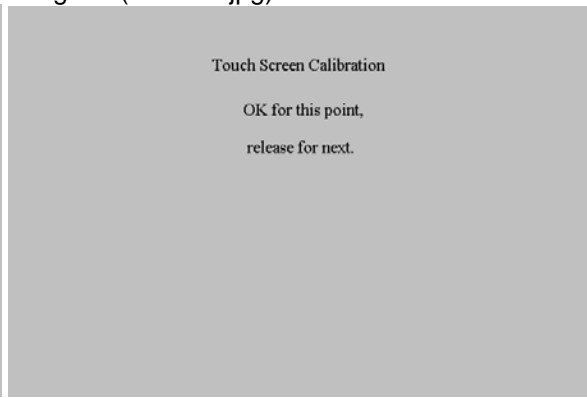

Fig.9 (file: 009.jpg)

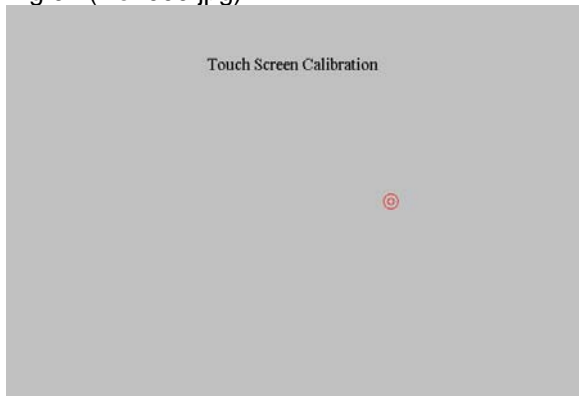

Fig. 16 (file: 016.jpg)

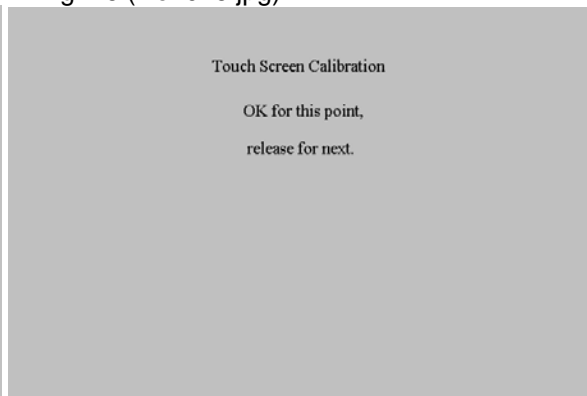

Fig.10 (file: 010.jpg)

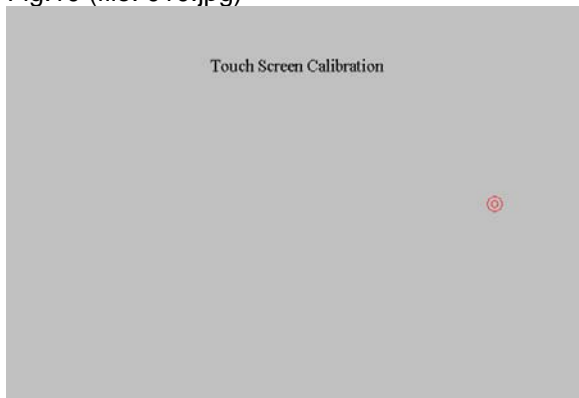

Fig. 16 (file: 016.jpg)

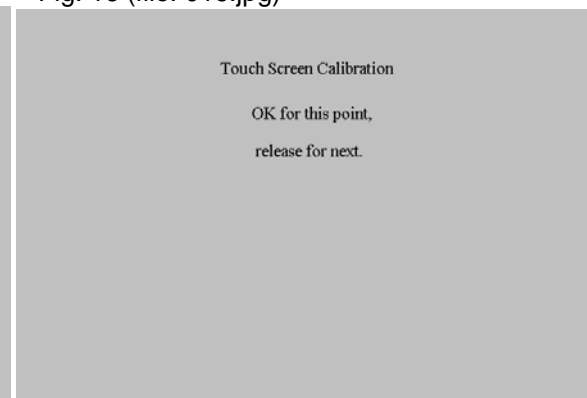

Fig.11 (file: 011.jpg)

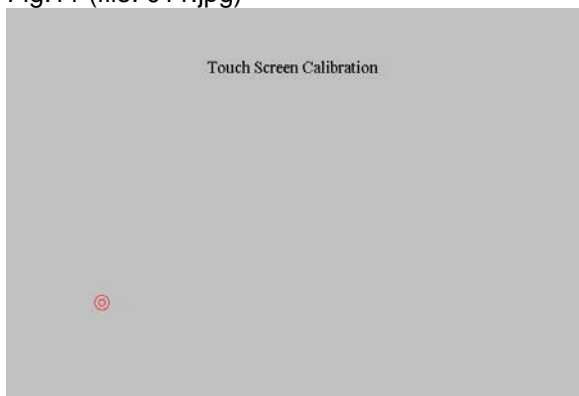

Fig. 16 (file: 016.jpg)

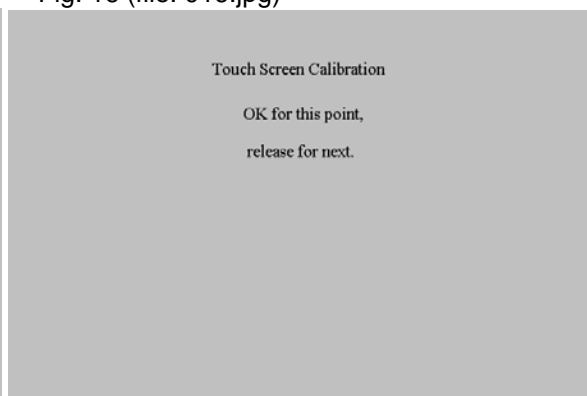

Fig.12 (file: 012.jpg)

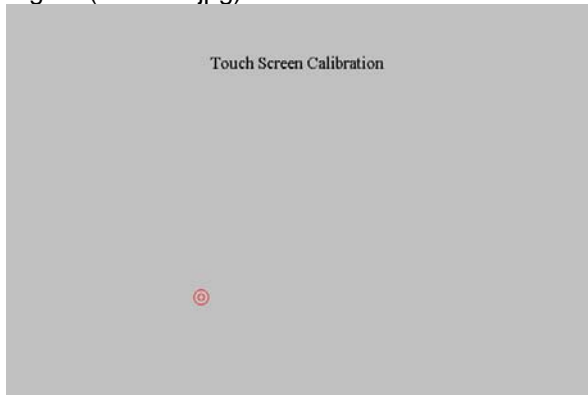

Fig. 16 (file: 016.jpg)

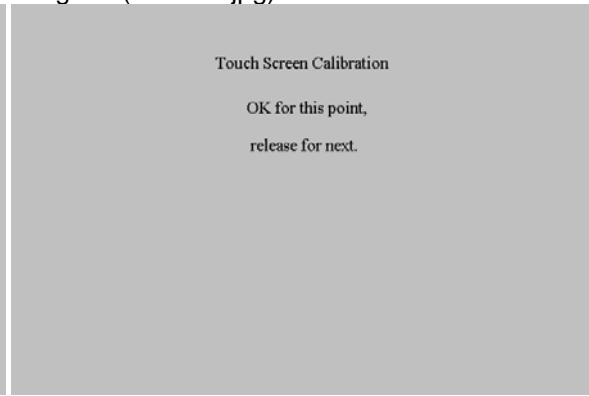

Fig.13 (file: 013.jpg)

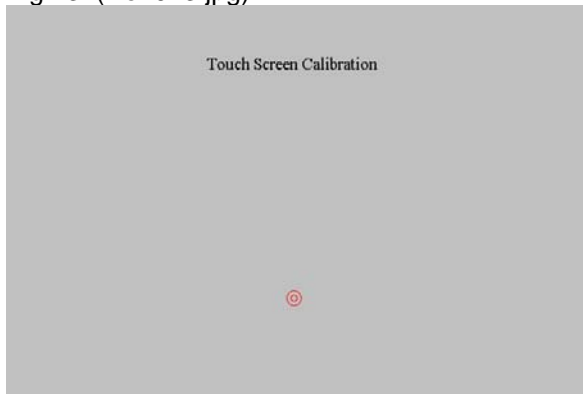

Fig. 16 (file: 016.jpg)

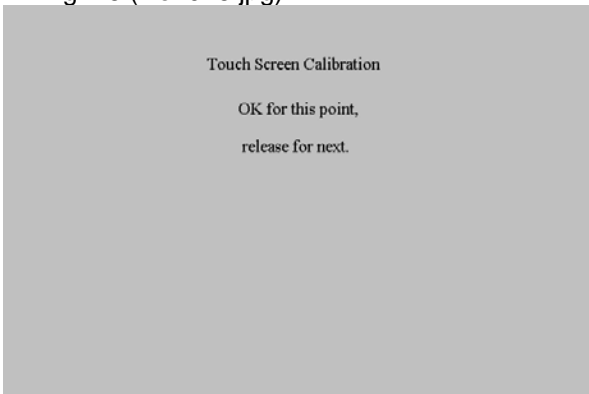

Fig.14 (file: 014.jpg)

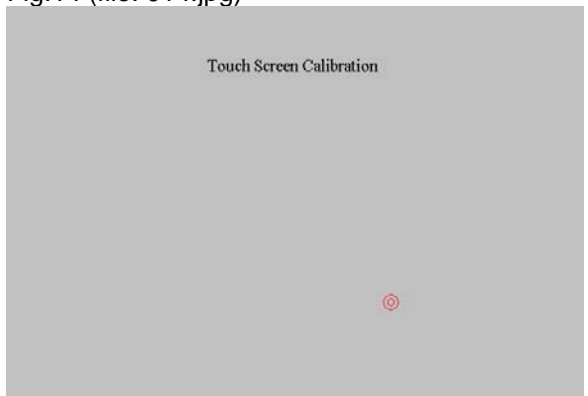

Fig. 16 (file: 016.jpg)

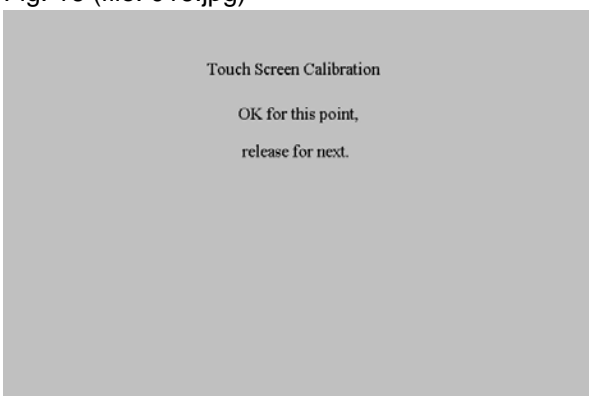

Fig.15 (file: 015.jpg)

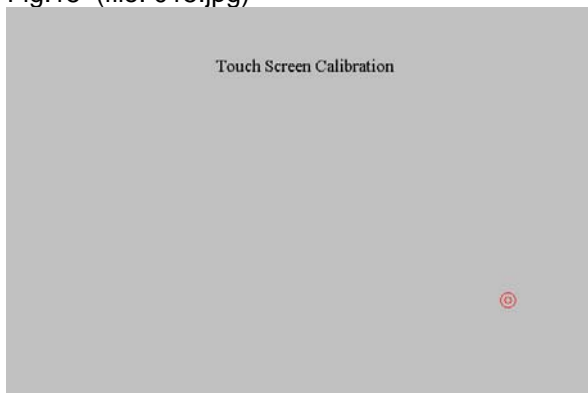

Fig. 16 (file: 016.jpg)

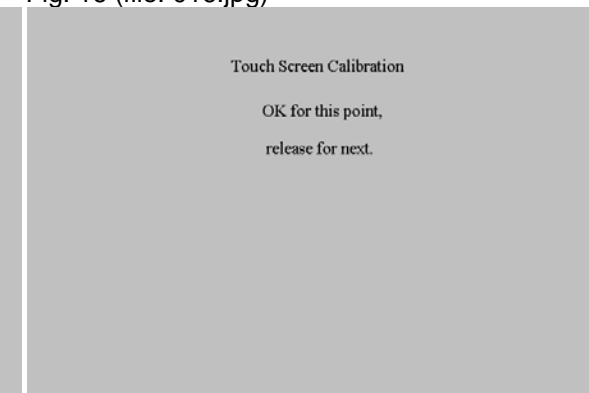

Fig.17 (file: 017.jpg)

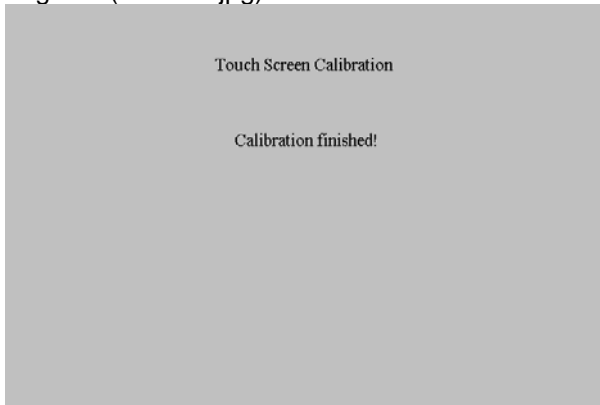

Fig.18. 6 x 4 matrix (not a file in the specific files).

1	2	3	4	5	6
7	8	9	10	11	12
13	14	15	16	17	18
19	20	21	22	23	24

- end -